

Load limiter for crane

CLG-SL Load limiter is an electronic device able to control the load of the crane (or another machine) through a pressure transducer, and limits the operations that would cause an overloading and/or an overturning of the machine, acting on the bypass valve.

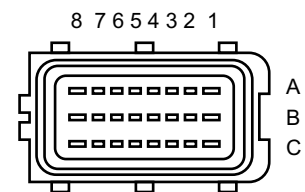

Overall dimensions: 138 x 110 (147 with connector) x 38 mm
Drilling interaxis: 119 x 99 mm (n° 4 screw M5)



Pinout FCI connector (24 ways)

A1 - Power supply	B1 - RX serial comm.	C1 - TX serial comm.
A2 - +V transducer supply	B2 - +V PRG2 supply	C2 - PRG2 ground signal
A3 - not used	B3 - ground for 90% signal	C3 - ground for 100% signal
A4 - +V switch supply	B4 - +ELV1 signal	C4 - not used
A5 - +V switch supply	B5 - ELV1 ground	C5 - not used
A6 - not used	B6 - input TRANSD. 1 (P)	C6 - input RESET
A7 - DV input	B7 - input DECREMENT	C7 - not used
A8 - Emergency input	B8 - Emergency output	C8 - GND

Features

Power supply range: from 10Vdc, up to 30Vdc.

Connector FCI, 24 ways, IP68, mechanical polarization, easy locking cam.

Maximum output current supply: 3A

According to EN 954-1 Safety Standards: Category 2

Two different working areas with two different load limits.

Fast and easy programming sequence.

Human machine interface

The green led on the board, in normal operation mode, is lighted to show the power supply.

When faults are present, the green led blinks following a particular sequence related to the fault reasons. (look at the last page for a detailed blinking sequence meaning).

Also, it is present a LED bargraph to show the load percentage in real time, compared to the maximum load. When the load exceeds the 100% of the limit, red LED of the bargraph blinks.

Leds placed into the emergency button box (red colour and yellow colour), are lighted in the following situations:

- When emergency button is pressed, the red and the yellow blink together.
- When the load exceeds the 90% of the limit, yellow led is ON.
- When the load exceeds the 100% of the limit, red led is ON.

The CLG-SL load limiter is able to control a Bar LED in order to signal when load exceed the 90% and 100% of maximum permitted load.

For this purpose, it is necessary open the box of secondary emergency push button and connect a cable as instructed below.

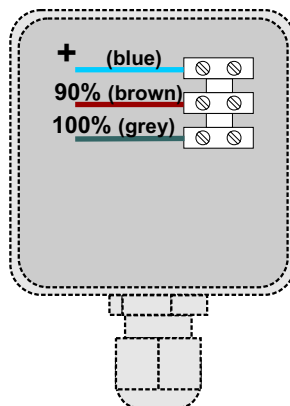

Inputs

- **RESET:** That input allows the load limiter to power the valve ELV1 for a short period, even if the load value exceeds the load limit. During this time, the user is able to move the machine in order to return into a safety position. Working conditions are not monitored when reset functionality is enabled, user is responsible for possible machine damage.
- **LIMIT REDUCTION** (critical working area): It is useful when a working area is more critical than other: when its value is low, a reduced pressure threshold is used.
- **INCREASE THRESHOLD** (optional): that input has to be coupled with first boom descent manoeuvre. When input value goes high, the load limit threshold is increased by a fixed value (specified in a configuration parameter), in order to offset the pressure increase due to overcenter valves which operate during this manoeuvre.
- **PRESSURE transducer** input: 4÷20 mA.
- **INPUT DV:** It allows to connect the load limiter to a remote control in a safety way.
- **DIFFERENT POWER SUPPLY** for powered outputs, which includes a disconnect relay with feedback control. Emergency button can be connected to this input.

Outputs

- Powered output to drive bypass valve coil. The board implements a feedback current control on the mentioned output.
- Two powered output to drive external optional lamps. The mentioned outputs are driven as well as the leds into emergency button box (90% and 100%).

Setting parameters by final user

The load limiter's thresholds are programmed using an external, little, 4 buttons, keyboard. The keyboard is an optional. Its name is "PRG-CLG". When it is connected the green led blinks four times in a second.

Hardware key to increase the load limit threshold

The PRG2 (either CLG version or DEC version) can be used even to increase the load limit threshold up to 125%, for a brief period of time.

In order to increase the limit: when you connect the PRG2, the "+" button has to be pressed within 5 seconds then kept pressed till the green led blinking will becomes slower.

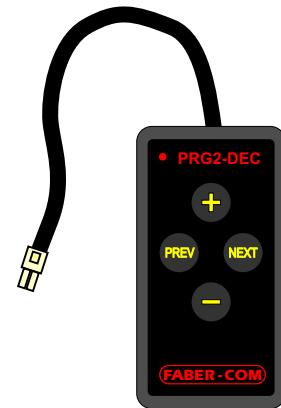

PC connection

In most cases, CLG load limiter doesn't need to be connected to PC:

- thresholds are programmed by means of PRG 2 keyboard
- fault analysis is done by means of the green LED placed near connector

It is possible to connect CLG card to PC with serial port using the special serial adapter AISM (code: PISPM) and free SepSim Windows® program.

PC connection is required in the following cases:

- to set whole the load limiter's parameters
- upload/download the working configuration
- to monitor some working parameters when fault occurs
- to update the firmware

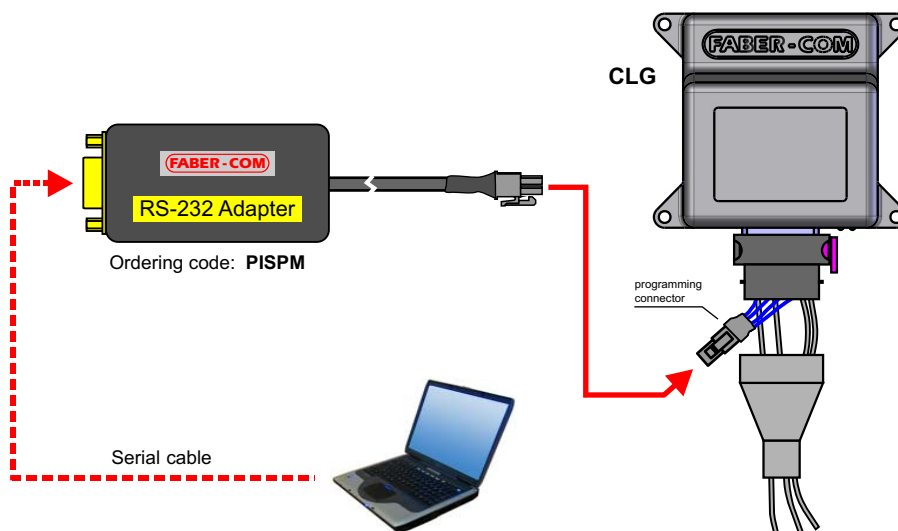

**ELECTRONIC BOARD
CLG**

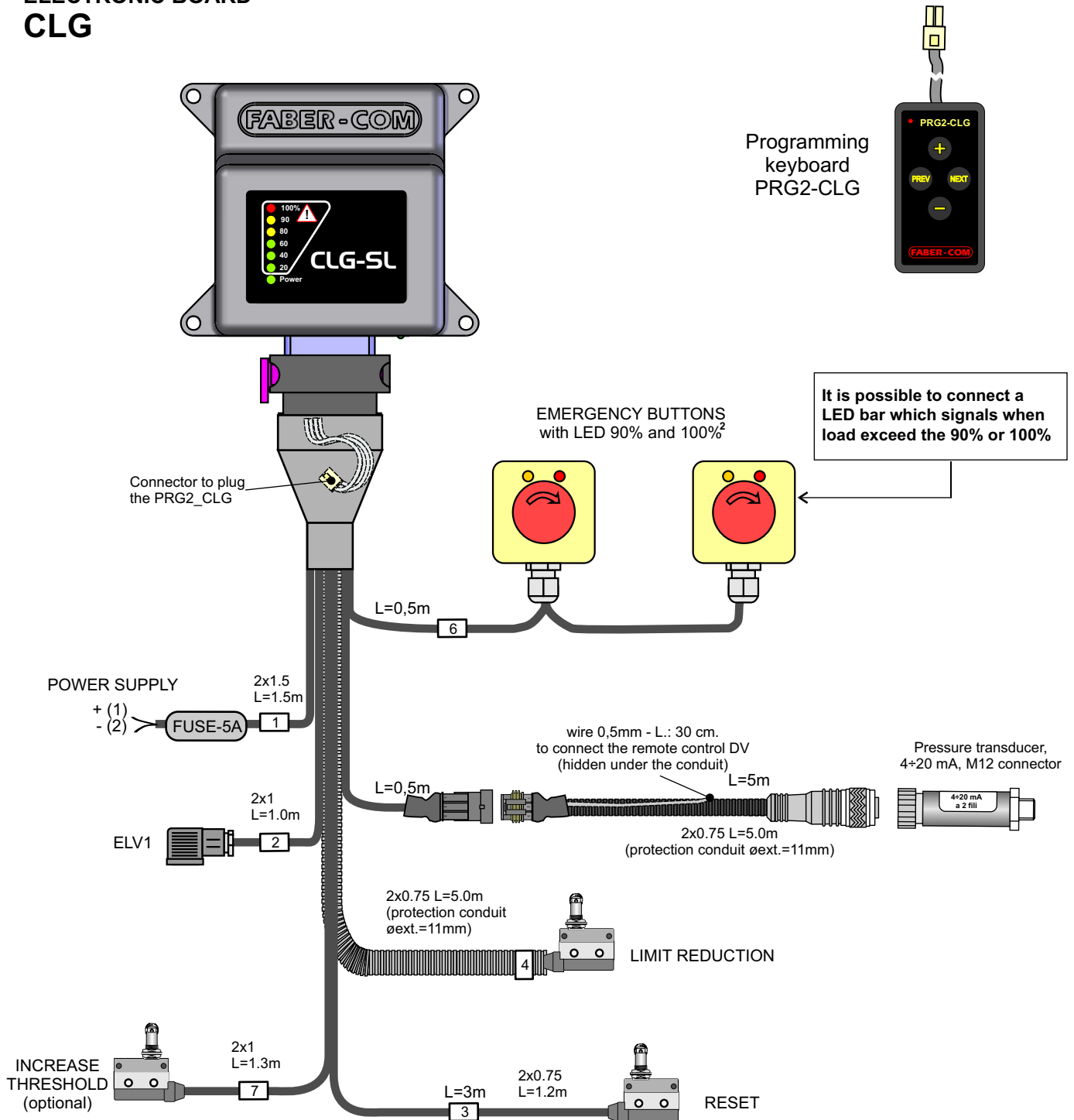

Ordering code

Code PASMLMxxx : Control unit CLG + cabling
 Code PCLG-LyE : Only control unit
 Code A1003720022 : 400bar Pressure transducer
 Code A1003720021 : 250bar Pressure transducer

Code PPRG2MC:programming keyboard

Ordering code of system shown in figure :
 Code PASMLM0027 : Control unit CLG + cabling
 Code A1003720022 : 400bar Pressure transducer

Error code

Here below you can see a table to summarize the green led blinking and a brief description of the related error.

CLG STATE	BLINKING		DESCRIPTION
	Slow sequence	Fast sequence	
WORKING STATE	1	1	Input from transducer 1 exceeds the maximum working limit.
	1	2	Input from transducer 1 is lower than minimum working value.
	2	1	Input from transducer 2 exceeds the maximum working limit.
	2	2	Input from transducer 2 is lower than minimum working value.
	3	1	The current value on the valve 1 is outside the normal working range.
	3	2	The current value on the valve 2 is outside the normal working range.
	4	2	The input transducer 1 is in protection mode.
	4	3	The input transducer 2 is in protection mode.
	4	4	Relay broken because of the welded contacts.
AUTOTEST	5	1	FLASH MEMORY ERROR.
	5	3	It is not possible to close the relay. The outputs are not powered.
	5	4	There is current flowing on the valve coil even though the CLG is not driving the related output.
	5	5	There is current flowing on the transducer even though the CLG gives no power to it.
	5	7	There is current flowing on switches even though the CLG gives no power to it.

CLG STATE	BLINKING	DESCRIPTION
ANY TIME	LED 100% + LED 90% blinking together	Emergency button pressed