

Tank mounted return line filters

HF 547 series



THE IMPORTANCE OF AN EFFICIENT FILTRATION

The main cause of anomalies in hydraulic systems has to be attributed to the presence of contaminants in the fluid.

The nature of the contaminant may be: gaseous, namely air mixed with the fluid; fluid, it depends on water penetrating the fluid; solid, therefore particles of various origins and dimensions.

Customers who operate equipments are always focused on obtaining the best possible performance, lower energy consumptions and greater respect for the environment.

These characteristics can be attained by using top quality components in the hydraulic system for generating and regulating the fluid power, which are also more sensitive to the presence of contaminants in the fluid.

Starting from these requirements, we understand how important and fundamental it is to prevent the presence of air and water from mixing in the fluid tank by using dedicated solutions.

It is also crucial to limit the presence of solid particles in the hydraulic circuit through a suitable filtering system, which is indispensable to maintain the project requirements of the system over time and to keep running costs low.

The correct choice of a filter and its optimum position in the hydraulic system requires the same care and experience needed to choose all the other components.

The use of filters with larger filtering surfaces reduces, at equal flow rates, the superficial contaminant load and therefore the filter's life is extended proportionally.

To maintain the maximum efficiency of the system, the filters must have a clogging indicator showing the differential pressure on the filtering cartridge and to immediately point out when the cartridge needs replacing in order to prevent the by-pass valve from opening.

The following factors should be analysed when choosing the ideal filter:

- The filtration degree required to protect the most sensitive component from contamination
- The points of the circuit in which the filters have to be installed
- The working pressure of the system
- The maximum flow rate and the type of fluid to be filtered
- The duty cycle
- The retention efficiency of the filtering cartridge
- The contaminant accumulation capacity of the filtering cartridge
- The working ambient temperature

Each filter used generates a pressure drop that increases continuously as time goes by. This pressure drop represents an efficiency index of the filter itself.

When the hydraulic system is about to be assembled, all the components must be perfectly clean and the fluid has to be added through a device complete with a filter.

During the test phase, it is advisable to run some work cycles at low pressure in order to create the best possible conditions for all the components.

TECHNICAL CHARACTERISTICS

The tank mounted filters HF 547 series are specifically designed to be directly connected on the return line of hydraulic circuits and provide versatility to safeguard the circuit components from contaminating particles. The standard filters are supplied with by-pass valve calibrated at 25 psi (1,7 bar).

- Flow up to 53 US gpm (200 l/min)
- Maximum working pressure 116 psi (8 bar)
- Pressurized air breather
- Antisplash system
- Anodized housing
- Level dipstick
- Bowl extension

MATERIALS

Cover	Reinforced nylon
Housing	Anodized aluminum
Bowl	Reinforced nylon Steel (on request)
Seals	Buna - Viton
End cap	Zinc plated steel
Inner tube	Zinc plated steel Steel Stainless steel
Filter media	Cellulose Reinforced cellulose Micro-fibre glass

FLUID COMPATIBILITY

Conforming to ISO 2943 (Norm ISO 6743/4)

Oli mineral (1)	HH - HL - HM - HR - HV - HG
Water emulsion (1)	HFAE - HFAS
Water glycol (1)	HFC
Syntetic fluid (2)	HS - HFDR - HFDU - HFDS

(1) With Buna seals

(2) With Viton seals

FLOW

Flow max.	53 US gpm (200 l/min)
-----------	-----------------------

PRESSURE

Working pressure	116 psi (8 bar)
Testing pressure	175 psi (12 bar)
Burst pressure	230 psi (16 bar)
Element collapse pressure rating (conforming to ISO 2941)	145 psi (10 bar)

BY-PASS VALVE

By-pass setting	25 psi (1,7 bar)
-----------------	------------------

OPERATING TEMPERATURE

With Buna seals	-22 ÷ 195 °F (-30 ÷ 90 °C)
With Viton seals	-4 ÷ 230 °F (-20 ÷ 110 °C)

DEGREE OF FILTRATION

Absolute Filtration

Code	Material	Degree of filtration
FG003	Micro-fibre glass	3 µm
FG006	Micro-fibre glass	6 µm
FG010	Micro-fibre glass	10 µm
FG025	Micro-fibre glass	25 µm

Nominal Filtration

Code	Material	Degree of filtration
SP010	Cellulose	10 µm
RP010	Reinforced cellulose	10 µm
SP025	Cellulose	25 µm
RP025	Reinforced cellulose	25 µm
MI025	Stainless steel	25 µm
MI060	Stainless steel	60 µm
MS090	Steel	90 µm
MI125	Stainless steel	125 µm

INDICATORS (3)

Rear manometer

Radial manometer

Visual indicator

Electrical indicator

(3) Characteristics and dimensions at page 18

SIZING – PRESSURE DROP

The total pressure drop of the filter is calculated by summing the pressure drop value in the housing to the one in the filtering element.

Total $\Delta p = \Delta p$ in housing + Δp in element

In filters of HF 547 series in normal working conditions, the total Δp must not be more than 5.8 psi (0,4 bar). To establish the values of pressure drop involved, the following pages provide some diagrams with curves referred to the use of mineral oils ISO VG46 with kinematic viscosity of 120 SSU (30 cSt) and density of 7.29 lb/gal (0,856 kg/dm³).

Calculation example

Filter HF547-20.201-AS-FG025-B17-GG-B-S-Z-XN-G-YN-A-K

Flow rate= 29 US gpm (110 l/min)

Kinematic viscosity: 120 SSU (30 cSt)

Oil density : 7.29 lb/gal (0,856 kg/dm³)

Filtering degree: 25 μ m

Data obtained from the diagrams:

Δp in housing = 2.00 psi (0,14 bar) (page 4)

Δp in element = 3,2 psi (0,22 bar) (page 8)

Total $\Delta p = 2.00 + 3.2 = 5.2$ psi (0,36 bar) (Δp is lower than maximum value admitted – therefore sizing is correct).

If oil with different kinematic viscosity and different density is used, the values obtained from the diagrams will be re-calculated considering the following indications:

1) The pressure drop of the housing is proportional with the oil density, therefore for oil with density different to 7.29 lb/gal (0,856 kg/dm³) the value of the Δp in the head-bowl will be:

$$\Delta p \text{ in housing} = \frac{\Delta p \text{ of diagram (psi)} \cdot \text{Oil density (lb/gal)}}{7.29 \text{ (lb/gal)}} \quad [\text{psi}]$$

Or

$$\Delta p \text{ in housing} = \frac{\Delta p \text{ of diagram (bar)} \cdot \text{Oil density (kg/dm}^3\text{)}}{0,856 \text{ (kg/dm}^3\text{)}} \quad [\text{bar}]$$

2) The pressure drop of the element is proportional with the oil density and kinematic viscosity, therefore for oil with density different to 7.29 lb/gal (0,856 kg/dm³) and kinematic viscosity different to 120 SSU (30 cSt) the value of Δp in the element will be:

$$\Delta p \text{ element} = \Delta p \text{ of diagram (psi)} \cdot \frac{\text{Oil density (lb/gal)}}{7.29 \text{ (lb/gal)}} \cdot \frac{\text{Oil viscosity (SSU)}}{120 \text{ (SSU)}} \quad [\text{psi}]$$

Or

$$\Delta p \text{ element} = \Delta p \text{ of diagram (bar)} \cdot \frac{\text{Oil density (kg/dm}^3\text{)}}{0,856 \text{ (kg/dm}^3\text{)}} \cdot \frac{\text{Oil viscosity (cSt)}}{30 \text{ (cSt)}} \quad [\text{bar}]$$

Now you sum the values of the pressure drop of the housing to the value of the pressure drop of the filtering element, always making sure the total Δp does not exceed the pressure limit of 5.8 psi (0,4 bar).

02/07.2012

PRESSURE DROP CURVES THROUGH THE BY-PASS VALVES

The pressure drop values are directly proportional with the specific weight of the fluid and do not affect the establishment of the total pressure drop of the complete filter.

The curves are obtained in the following conditions:
 Mineral oil type ISO VG46
 Kinematic viscosity 120 SSU (30 cSt)
 Density 7.29 lb/gal (0,856 kg/dm³).

HF 547-10

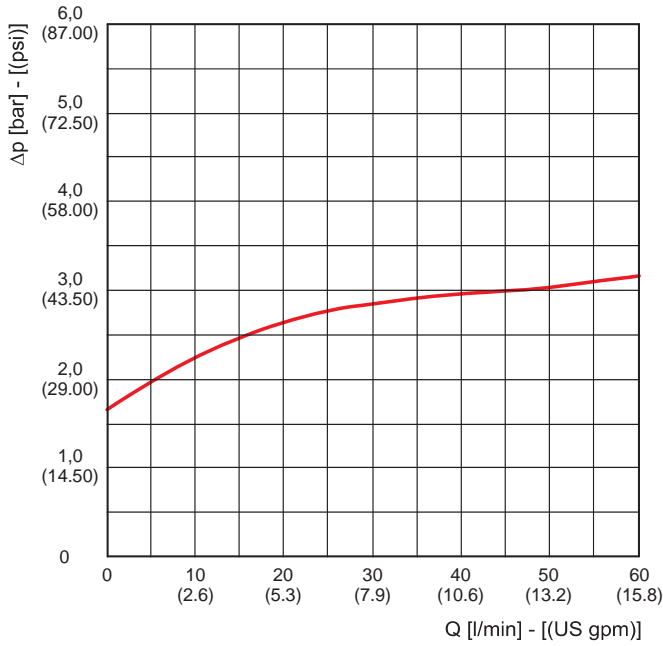

HF 547-20

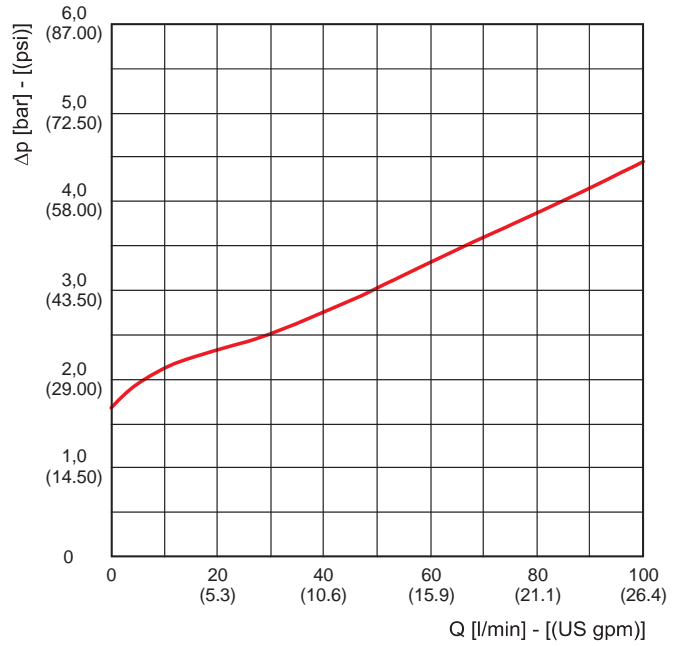

02/07.2012

PRESSURE DROP CURVES THROUGH THE HOUSING

The curves are obtained in the following conditions:
 Mineral oil type ISO VG46
 Kinematic viscosity 120 SSU (30 cSt)
 Density 7.29 lb/gal (0,856 kg/dm³).

- (1) G 3/8
- (2) G 1/2
- (3) G 3/4
- (4) G 1
- (5) G 1 1/4

HF 547-10

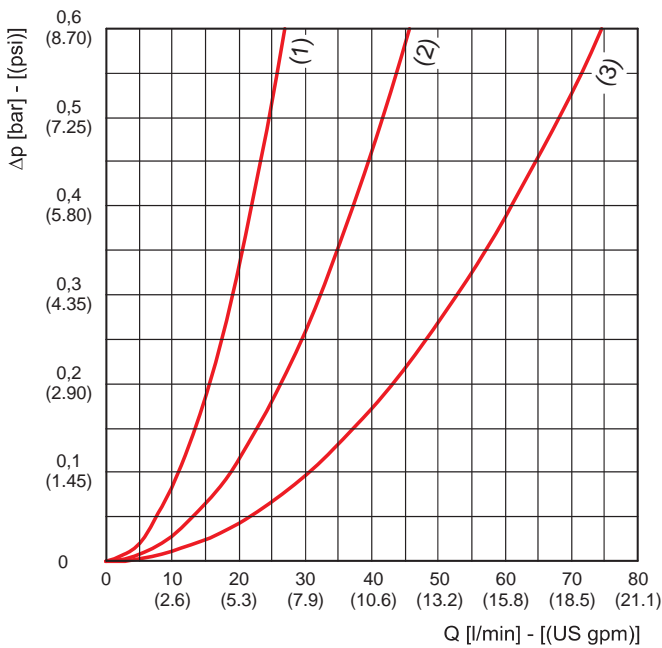

HF 547-20.077 / 20.122

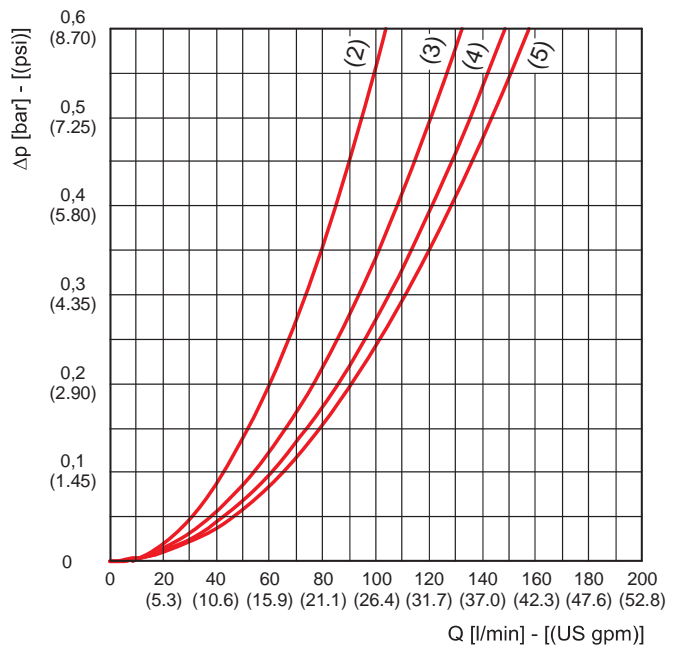

HF 547-20.201 / 20.280

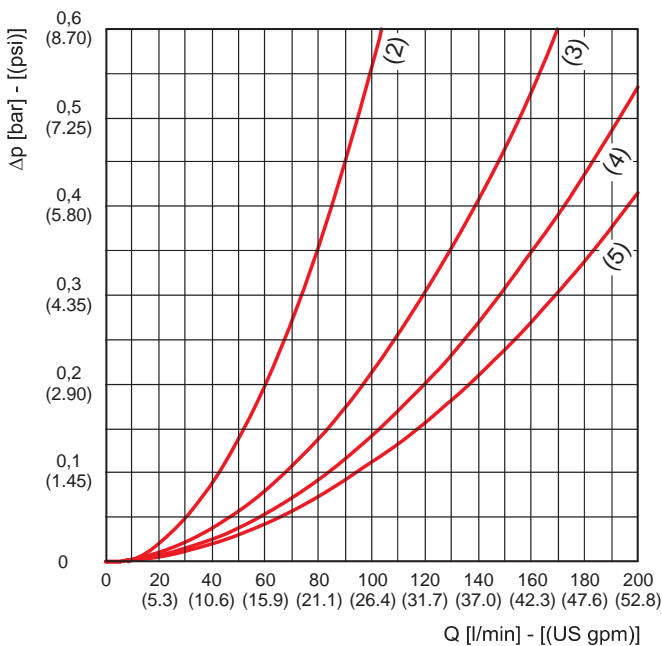

02/07.2012

PRESSURE DROP CURVES THROUGH THE ELEMENT HEK02-08

The curves are obtained in the following conditions:
 Mineral oil type ISO VG46
 Kinematic viscosity 120 SSU (30 cSt)
 Density 7.29 lb/gal (0,856 kg/dm³).

- (1) HE K02-08.095
- (2) HE K02-08.145
- (3) HE K02-08.195

FG003

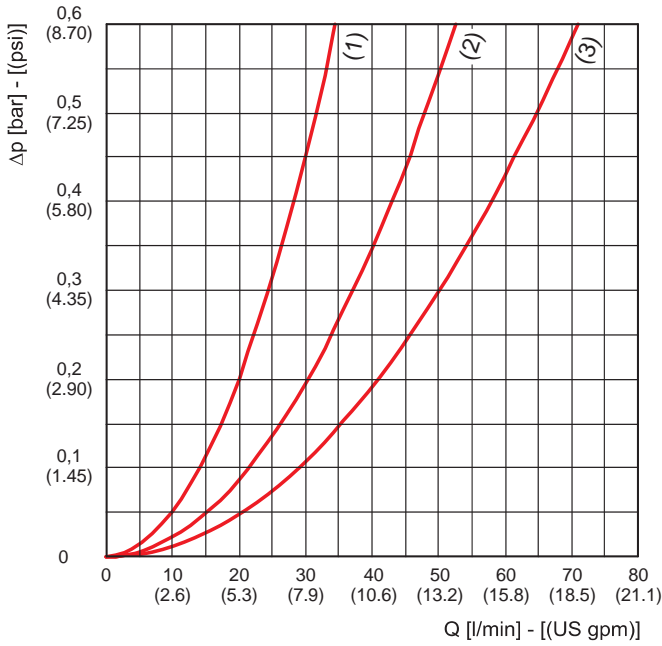

FG006

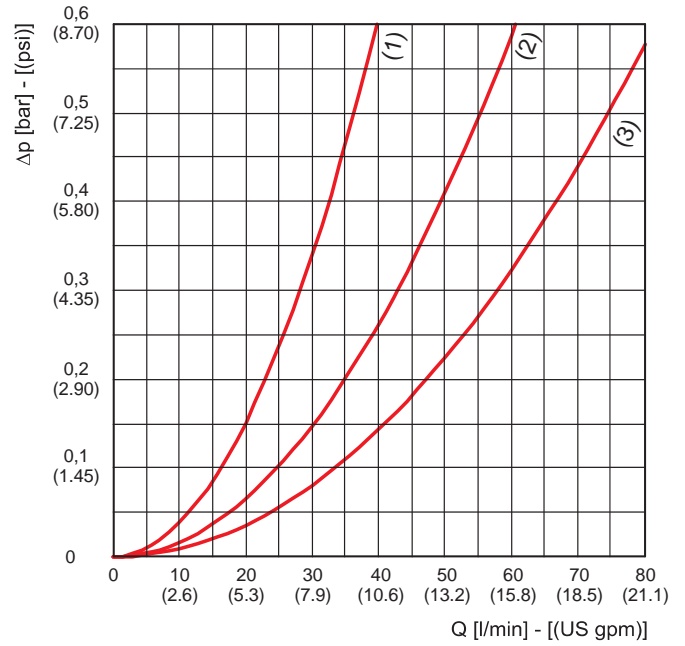

FG010

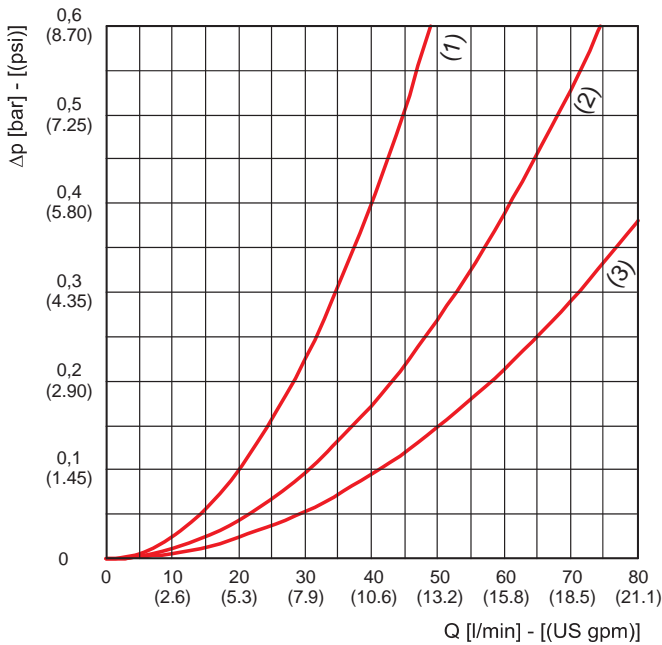

FG025

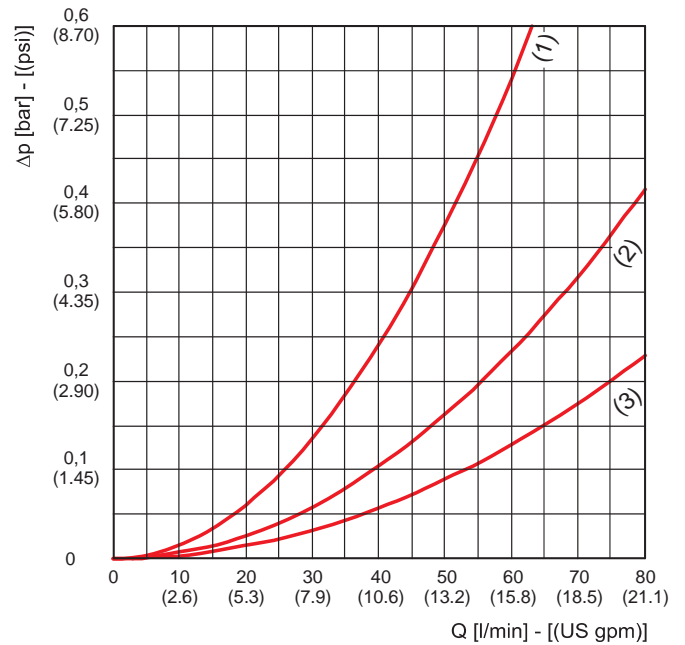

02/07.2012

PRESSURE DROP CURVES THROUGH THE ELEMENT HEK02-08

The curves are obtained in the following conditions:
 Mineral oil type ISO VG46
 Kinematic viscosity 120 SSU (30 cSt)
 Density 7.29 lb/gal (0,856 kg/dm³).

- (1) HE K02-08.095
- (2) HE K02-08.145
- (3) HE K02-08.195

MI025

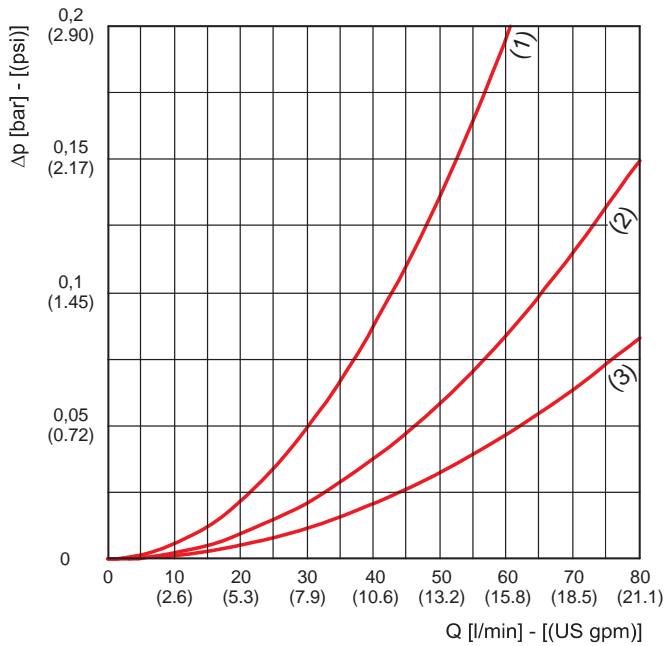

MI060

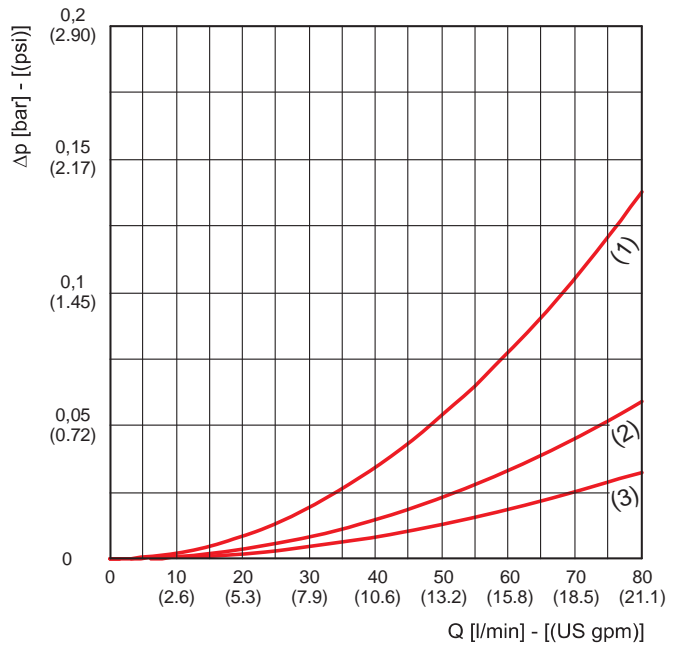

MS090

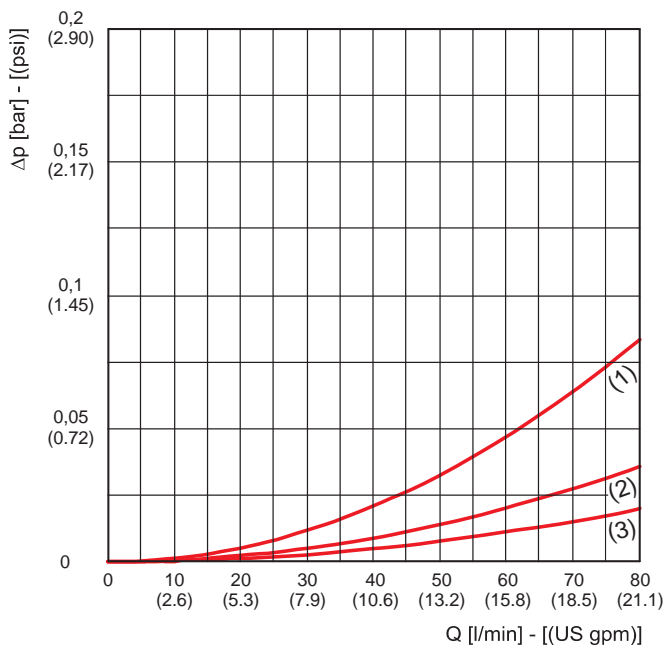

MI125

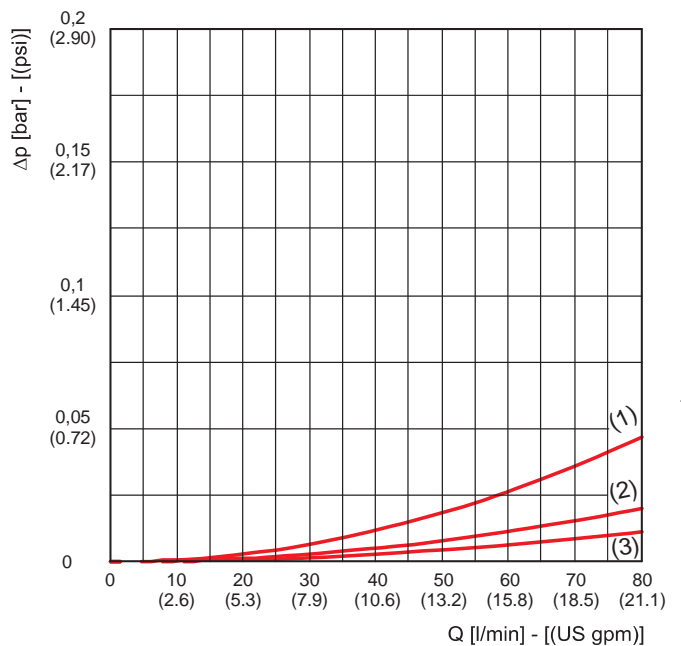

02/07.2012

PRESSURE DROP CURVES THROUGH THE ELEMENT HEK02-08

The curves are obtained in the following conditions:
 Mineral oil type ISO VG46
 Kinematic viscosity 120 SSU (30 cSt)
 Density 7.29 lb/gal (0,856 kg/dm³).

- (1) HE K02-08.095
- (2) HE K02-08.145
- (3) HE K02-08.195

RP010 / SP010

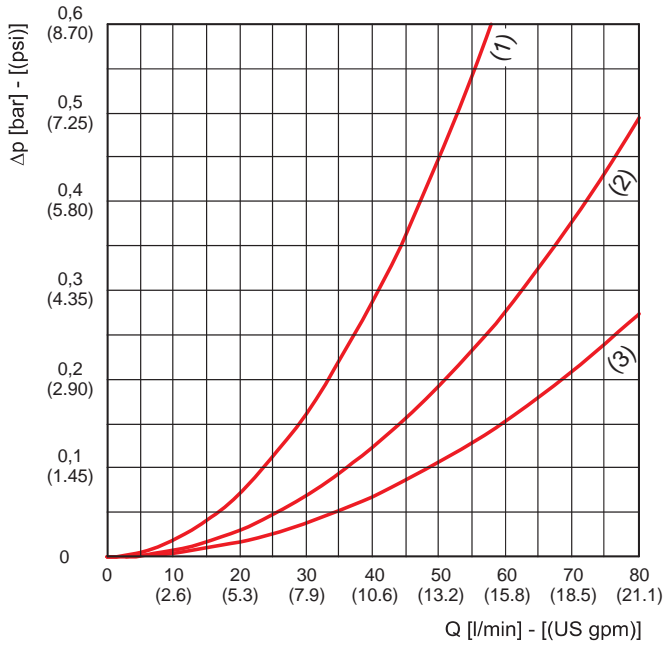

RP025 / SP025

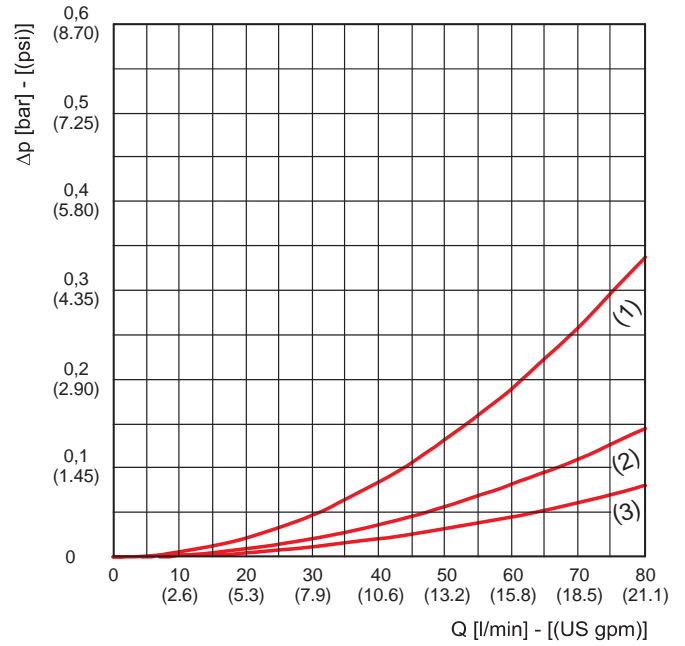

02/07.2012

PRESSURE DROP CURVES THROUGH THE ELEMENT HEK02-20

The curves are obtained in the following conditions:

Mineral oil type ISO VG46

Kinematic viscosity 120 SSU (30 cSt)

Density 7.29 lb/gal (0,856 kg/dm³).

(1) HEK02-20.077

(2) HEK02-20.122

(3) HEK02-20.201

(4) HEK02-20.280

FG003

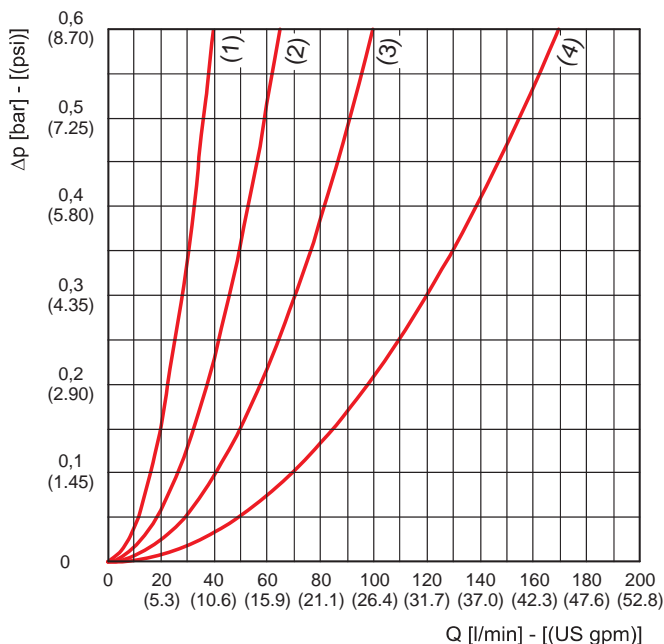

FG006

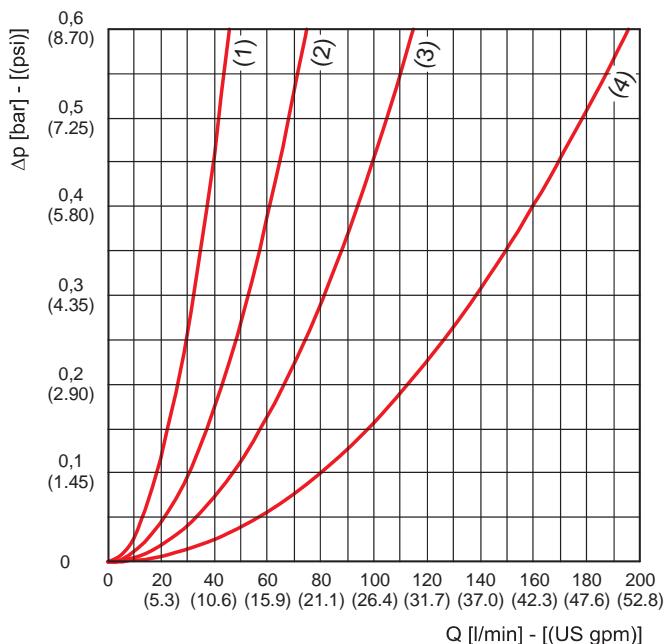

FG010

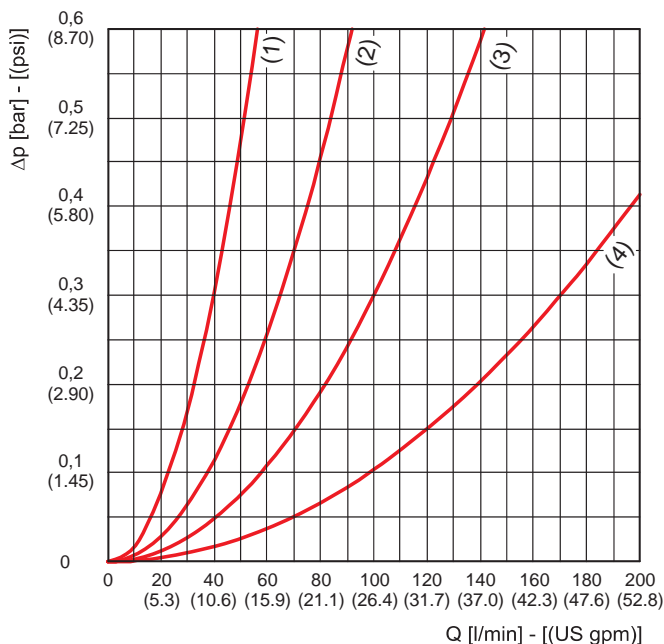

FG025

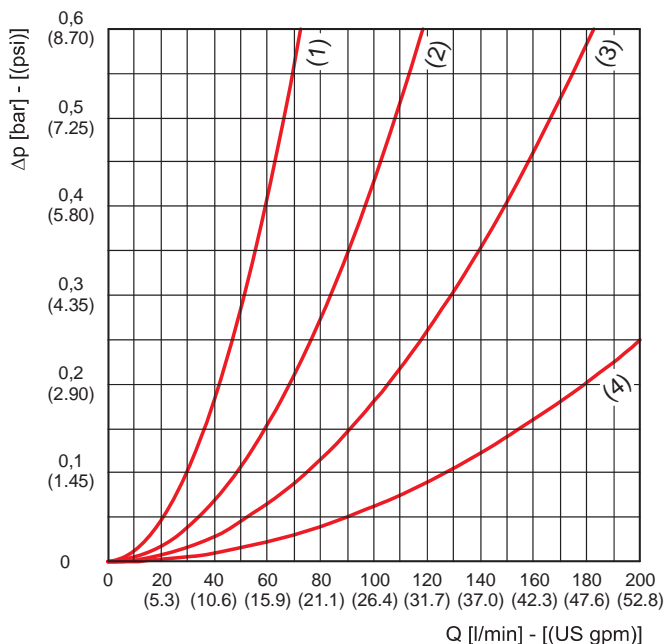

02/07.2012

PRESSURE DROP CURVES THROUGH THE ELEMENT HEK02-20

The curves are obtained in the following conditions:
 Mineral oil type ISO VG46
 Kinematic viscosity 120 SSU (30 cSt)
 Density 7.29 lb/gal (0,856 kg/dm³).

- (1) HEK02-20.077
- (2) HEK02-20.122
- (3) HEK02-20.201
- (4) HEK02-20.280

MI025

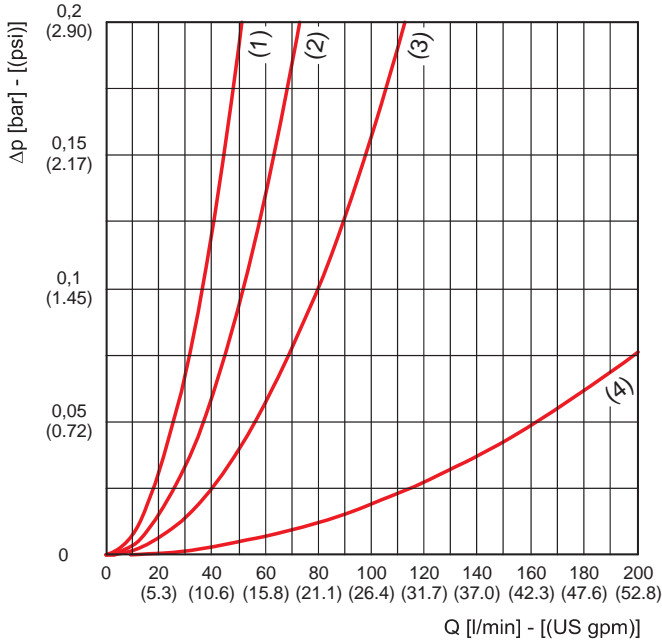

MI060

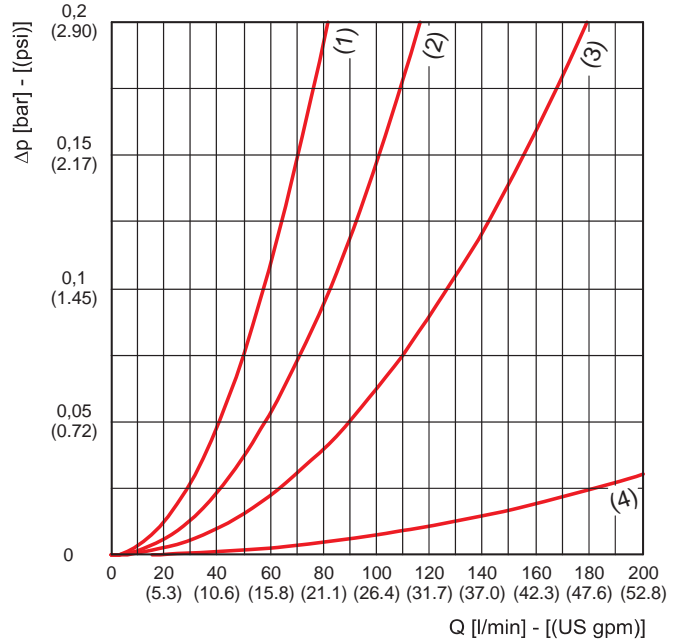

MS090

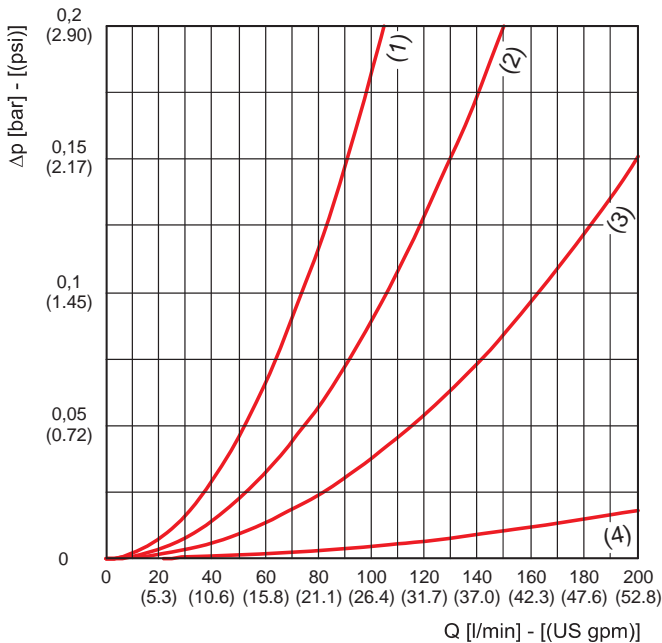

MI125

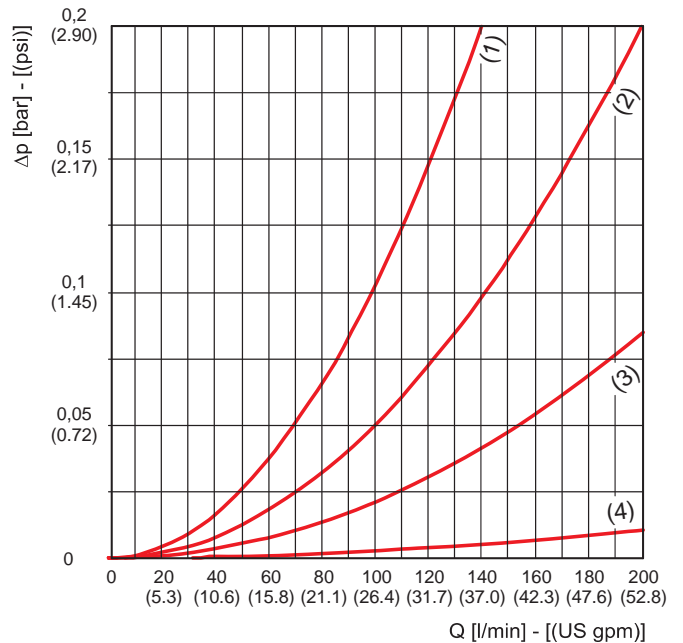

02/07.2012

PRESSURE DROP CURVES THROUGH THE ELEMENT HEK02-20

The curves are obtained in the following conditions:

Mineral oil type ISO VG46

Kinematic viscosity 120 SSU (30 cSt)

Density 7.29 lb/gal (0,856 kg/dm³).

(1) HEK02-20.077

(2) HEK02-20.122

(3) HEK02-20.201

(4) HEK02-20.280

RP010 / SP010

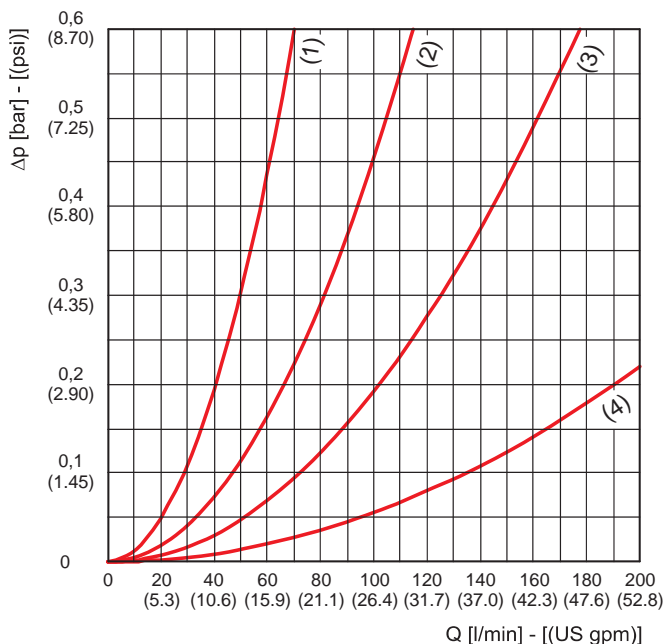

RP025 / SP025

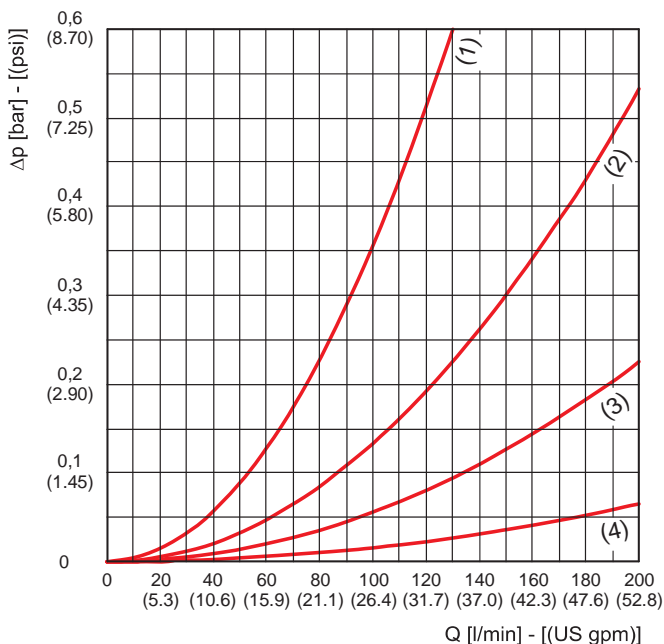

MICRO-FIBRE GLASS FLOWS

Filter type	Ports			Degree of filtration			
				FG003	FG006	FG010	FG025
	GAS (BSPP)	NPT	SAE J514b	Flow $\Delta p = 5.8$ psi (0,4 bar) ("AS" version values) US gpm (l/min)			
HF 547-10.095	G 3/8	3/8 NPT	9/16-18 UNF-2B	4.0 (15)	4.0 (15)	5.3 (20)	5.3 (20)
	G 1/2	1/2 NPT	3/4-16 UNF-2B	5.3 (20)	5.3 (20)	6.6 (25)	7.9 (30)
	G 3/4	3/4 NPT	1 1/16-12 UNF-2B	6.6 (25)	6.6 (25)	7.9 (30)	10.6 (40)
HF 547-10.145	G 3/8	3/8 NPT	9/16-18 UNF-2B	5.3 (20)	5.3 (20)	5.3 (20)	5.3 (20)
	G 1/2	1/2 NPT	3/4-16 UNF-2B	6.6 (25)	7.9 (30)	7.9 (30)	9.2 (35)
	G 3/4	3/4 NPT	1 1/16-12 UNF-2B	9.2 (35)	9.2 (35)	10.6 (40)	13.2 (50)
HF 547-10.195	G 3/8	3/8 NPT	9/16-18 UNF-2B	5.3 (20)	5.3 (20)	5.3 (20)	5.3 (20)
	G 1/2	1/2 NPT	3/4-16 UNF-2B	7.9 (30)	7.9 (30)	9.2 (35)	9.2 (35)
	G 3/4	3/4 NPT	1 1/16-12 UNF-2B	10.6 (40)	11.9 (45)	13.2 (50)	14.5 (55)
HF 547-20.077	G 1/2	1/2 NPT	3/4-16 UNF-2B	7.9 (30)	7.9 (30)	10.6 (40)	13.2 (50)
	G 3/4	3/4 NPT	1 1/16-12 UNF-2B	7.9 (30)	7.9 (30)	10.6 (40)	13.2 (50)
	G 1	1 NPT	1 5/16-12 UNF-2B	7.9 (30)	7.9 (30)	10.6 (40)	13.2 (50)
	G 1 1/4	1 1/4 NPT	1 5/8-12 UNF-2B	7.9 (30)	7.9 (30)	10.6 (40)	13.2 (50)
HF 547-20.122	G 1/2	1/2 NPT	3/4-16 UNF-2B	10.6 (40)	13.2 (50)	15.9 (60)	15.9 (60)
	G 3/4	3/4 NPT	1 1/16-12 UNF-2B	10.6 (40)	13.2 (50)	15.9 (60)	18.5 (70)
	G 1	1 NPT	1 5/16-12 UNF-2B	13.2 (50)	13.2 (50)	15.9 (60)	18.5 (70)
	G 1 1/4	1 1/4 NPT	1 5/8-12 UNF-2B	13.2 (50)	13.2 (50)	15.9 (60)	21.1 (80)
HF 547-20.201	G 3/4	3/4 NPT	1 1/16-12 UNF-2B	18.5 (70)	21.1 (80)	23.8 (90)	26.4 (100)
	G 1	1 NPT	1 5/16-12 UNF-2B	18.5 (70)	21.1 (80)	23.8 (90)	29.0 (110)
	G 1 1/4	1 1/4 NPT	1 5/8-12 UNF-2B	18.5 (70)	21.1 (80)	26.4 (100)	31.7 (120)
HF 547-20.280	G 3/4	3/4 NPT	1 1/16-12 UNF-2B	26.4 (100)	29.0 (110)	29.0 (110)	31.7 (120)
	G 1	1 NPT	1 5/16-12 UNF-2B	29.0 (110)	31.7 (120)	34.3 (130)	37.0 (140)
	G 1 1/4	1 1/4 NPT	1 5/8-12 UNF-2B	29.0 (110)	31.7 (120)	37.0 (140)	42.3 (160)

02/07.2012

CELLULOSE FLOWS

Filter type	Ports			Degree of filtration	
				RP010 / SP010	RP025 / SP025
	GAS (BSPP)	NPT	SAE J514b	Flow $\Delta p = 5.8$ psi (0,4 bar) ("AS" version values) US gpm (l/min)	
HF 547-10.095	G 3/8	3/8 NPT	9/16-18 UNF-2B	5.3 (20)	5.3 (20)
	G 1/2	1/2 NPT	3/4-16 UNF-2B	7.9 (30)	9.2 (35)
	G 3/4	3/4 NPT	1 1/16-12 UNF-2B	9.2 (35)	13.2 (50)
HF 547-10.145	G 3/8	3/8 NPT	9/16-18 UNF-2B	5.3 (20)	5.3 (20)
	G 1/2	1/2 NPT	3/4-16 UNF-2B	7.9 (30)	9.2 (35)
	G 3/4	3/4 NPT	1 1/16-12 UNF-2B	11.9 (45)	14.5 (55)
HF 547-10.195	G 3/8	3/8 NPT	9/16-18 UNF-2B	5.3 (20)	5.3 (20)
	G 1/2	1/2 NPT	3/4-16 UNF-2B	9.2 (35)	9.2 (35)
	G 3/4	3/4 NPT	1 1/16-12 UNF-2B	13.2 (50)	15.9 (60)
HF 547-20.077	G 1/2	1/2 NPT	3/4-16 UNF-2B	13.2 (50)	15.9 (60)
	G 3/4	3/4 NPT	1 1/16-12 UNF-2B	13.2 (50)	18.5 (70)
	G 1	1 NPT	1 5/16-12 UNF-2B	13.2 (50)	21.1 (80)
	G 1 1/4	1 1/4 NPT	1 5/8-12 UNF-2B	13.2 (50)	21.1 (80)
HF 547-20.122	G 1/2	1/2 NPT	3/4-16 UNF-2B	15.9 (60)	21.1 (80)
	G 3/4	3/4 NPT	1 1/16-12 UNF-2B	18.5 (70)	23.8 (90)
	G 1	1 NPT	1 5/16-12 UNF-2B	18.5 (70)	26.4 (100)
	G 1 1/4	1 1/4 NPT	1 5/8-12 UNF-2B	18.5 (70)	26.4 (100)
HF 547-20.201	G 3/4	3/4 NPT	1 1/16-12 UNF-2B	26.4 (100)	31.7 (120)
	G 1	1 NPT	1 5/16-12 UNF-2B	29.0 (110)	39.7 (150)
	G 1 1/4	1 1/4 NPT	1 5/8-12 UNF-2B	31.7 (120)	42.3 (160)
HF 547-20.280	G 3/4	3/4 NPT	1 1/16-12 UNF-2B	31.7 (120)	37.0 (140)
	G 1	1 NPT	1 5/16-12 UNF-2B	39.7 (150)	44.9 (170)
	G 1 1/4	1 1/4 NPT	1 5/8-12 UNF-2B	42.3 (160)	50.2 (190)

02/07.2012

STEEL WIRE MESH FLOWS

Filter type	Ports			Degree of filtration			
				MI025	MI060	MS090	MI125
				Flow $\Delta p = 5.8$ psi (0,4 bar) ("AS" version values)			
GAS (BSPP)	NPT	SAE J514b	US gpm (l/min)				
HF 547-10.095	G 3/8	3/8 NPT	9/16-18 UNF-2B	5.3 (20)	5.3 (20)	5.3 (20)	5.3 (20)
	G 1/2	1/2 NPT	3/4-16 UNF-2B	9.2 (35)	9.2 (35)	9.2 (35)	9.2 (35)
	G 3/4	3/4 NPT	1 1/16-12 UNF-2B	13.2 (50)	14.5 (55)	15.9 (60)	15.9 (60)
HF 547-10.145	G 3/8	3/8 NPT	9/16-18 UNF-2B	5.3 (20)	5.3 (20)	5.3 (20)	5.3 (20)
	G 1/2	1/2 NPT	3/4-16 UNF-2B	9.2 (35)	9.2 (35)	9.2 (35)	9.2 (35)
	G 3/4	3/4 NPT	1 1/16-12 UNF-2B	14.5 (55)	15.9 (60)	15.9 (60)	15.9 (60)
HF 547-10.195	G 3/8	3/8 NPT	9/16-18 UNF-2B	5.3 (20)	5.3 (20)	5.3 (20)	5.3 (20)
	G 1/2	1/2 NPT	3/4-16 UNF-2B	9.2 (35)	9.2 (35)	9.2 (35)	9.2 (35)
	G 3/4	3/4 NPT	1 1/16-12 UNF-2B	15.9 (60)	15.9 (60)	15.9 (60)	15.9 (60)
HF 547-20.077	G 1/2	1/2 NPT	3/4-16 UNF-2B	13.2 (50)	18.5 (70)	18.5 (70)	21.1 (80)
	G 3/4	3/4 NPT	1 1/16-12 UNF-2B	15.9 (60)	21.1 (80)	23.8 (90)	23.8 (90)
	G 1	1 NPT	1 5/16-12 UNF-2B	15.9 (60)	21.1 (80)	23.8 (90)	26.4 (100)
	G 1 1/4	1 1/4 NPT	1 5/8-12 UNF-2B	15.9 (60)	23.8 (90)	26.4 (100)	29.0 (110)
HF 547-20.122	G 1/2	1/2 NPT	3/4-16 UNF-2B	15.9 (60)	18.5 (70)	21.1 (80)	21.1 (80)
	G 3/4	3/4 NPT	1 1/16-12 UNF-2B	18.5 (70)	23.8 (90)	26.4 (100)	26.4 (100)
	G 1	1 NPT	1 5/16-12 UNF-2B	21.1 (80)	26.4 (100)	29.0 (110)	29.0 (110)
	G 1 1/4	1 1/4 NPT	1 5/8-12 UNF-2B	21.1 (80)	26.4 (100)	29.0 (110)	31.7 (120)
HF 547-20.201	G 3/4	3/4 NPT	1 1/16-12 UNF-2B	26.4 (100)	31.7 (120)	34.3 (130)	34.3 (130)
	G 1	1 NPT	1 5/16-12 UNF-2B	31.7 (120)	37.0 (140)	39.7 (150)	42.3 (160)
	G 1 1/4	1 1/4 NPT	1 5/8-12 UNF-2B	31.7 (120)	42.3 (160)	44.9 (170)	47.6 (180)
HF 547-20.280	G 3/4	3/4 NPT	1 1/16-12 UNF-2B	34.3 (130)	37.0 (140)	37.0 (140)	37.0 (140)
	G 1	1 NPT	1 5/16-12 UNF-2B	42.3 (160)	44.9 (170)	44.9 (170)	44.9 (170)
	G 1 1/4	1 1/4 NPT	1 5/8-12 UNF-2B	44.9 (170)	50.2 (190)	52.8 (200)	52.8 (200)

02/07.2012

HF547-10 DIMENSIONS

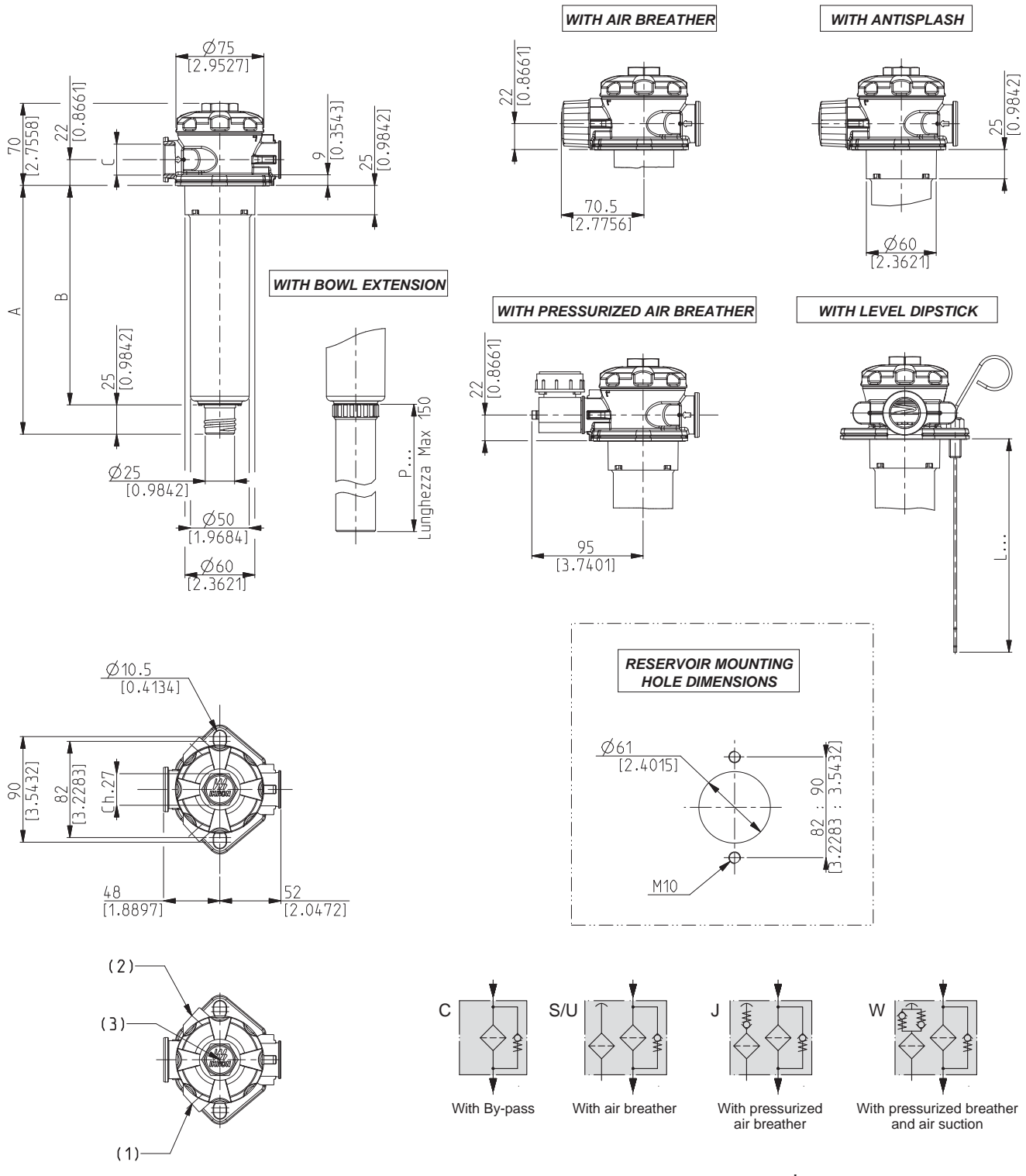

ICAT_021_002_HF547

02/07.2012

* Antifoam diffusers are available.

Filter type	Weight kg(lbs)	A mm(in)	B mm(in)	C (GAS - BSPP)		(1)(2)(3) (GAS-BSPP) Secondary inlet Standard	(1)(2)(3) (GAS - BSPP) Indicators
				Standard	On request		
HF 547-10.095	0,50 (1.10)	112 (4.4094)	87 (3.4251)	G 1/2	G 3/8 - G 3/4		
HF 547-10.145	0,55 (1.21)	162 (6.3779)	137 (5.3936)	G 3/4	G 3/8 - G 1/2	G 1/4 (1)-(2) G 1/2 (3)	G 1/8
HF 547-10.195	0,60 (1.32)	212 (8.3464)	187 (7.3621)				

NPT, metric and SAE UN-UNF threads are available (consult our technical department).

HF547-20 DIMENSIONS

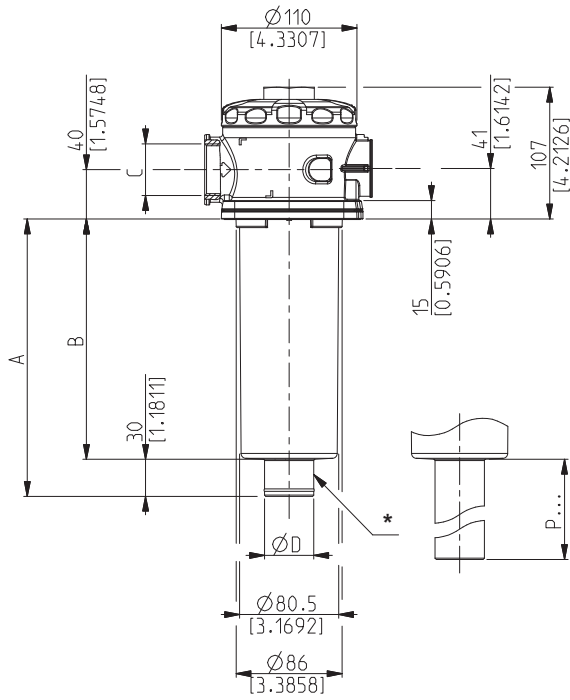

WITH AIR BREATHER

WITH ANTISPLASH

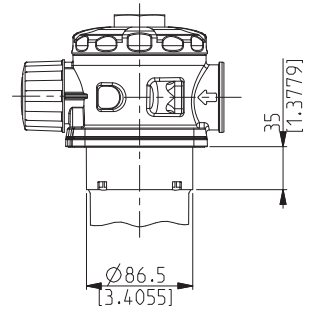
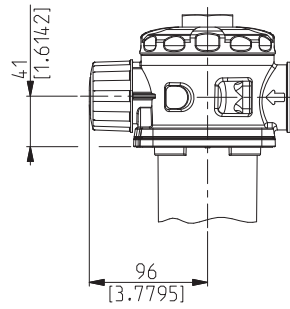

WITH PRESSURIZED AIR BREATHER

WITH LEVEL DIPSTICK

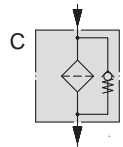
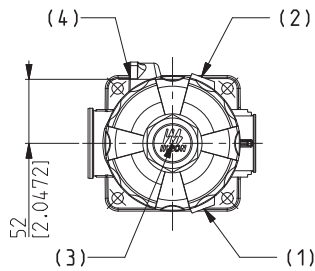
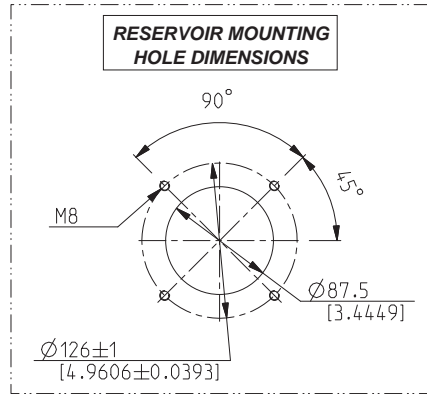
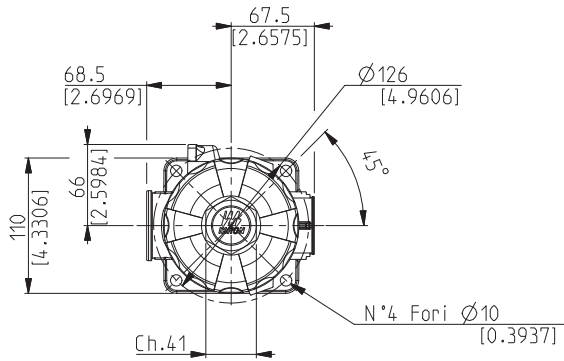
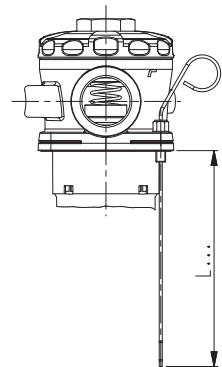
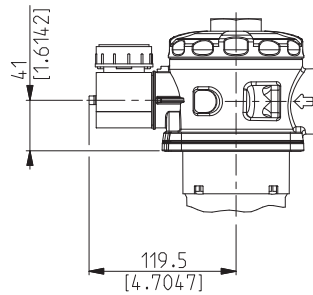

With By-pass

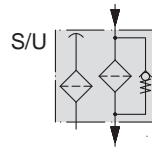

With air breather

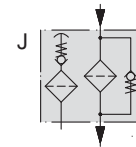

With pressurized air breather

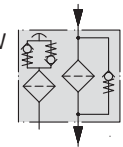

With pressurized breather and air suction

* Flexible extension bowls and antifoam diffusers are available.

Filter type	Weight kg(lbs)	A mm(in)	B mm(in)	C (GAS - BSPP)		ØD mm(in)	(3)(4) (GAS - BSPP) Secondary inlet		(1)(2)(3) (GAS-BSPP) Indicators	
				Standard	On request		Standard	On request	Standard	On request
HF 547-20.077	1.10 (2.42)	99 (3.8976)	69 (2.7165)	G 3/4	G 1/2 - G 1 - G 1 1/4	27,5 (1.0826)				
HF 547-20.122	1.20 (2.64)	144 (5.6692)	114 (4.4881)	G 1	G 1/2 - G 3/4 - G 1 1/4		G 3/8	G 1/2		G 1/8
HF 547-20.201	1.40 (3.08)	225 (8.8582)	195 (7.6771)							
HF 547-20.280	1.70 (3.74)	304 (11.9684)	274 (10.7874)	G 1 1/4	G 1/2 - G 3/4 - G 1	40 (1.5747)				

NPT, metric and SAE UN-UNF threads are available (consult our technical department).

02/07.2012

ICAT_021_001_HF547

ELEMENTS DIMENSIONS FOR HF547-10

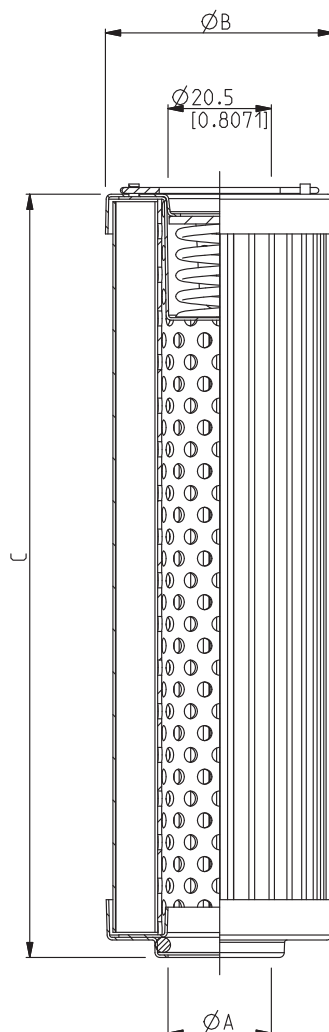

ICAT_021.003_HF547

Technical data for (FS) version elements are available on request.

Element Type	Ø A	Ø B	C	Filtering surface (AS)		
				FG	MI / MS	RP / SP
	mm (in)	mm (in)	mm (in)	cm ² (in ²)	cm ² (in ²)	cm ² (in ²)
HE K02-08.095			101,5 (3.9960)	565 (87.5751)	485 (75.1751)	645 (99.9752)
HE K02-08.145	20.5 (0.8070)	45 (1.7716)	151,5 (5.9645)	860 (133.3003)	740 (114.7002)	985 (148.4903)
HE K02-08.195			201,5 (7.9330)	1160 (179.8004)	995 (154.2253)	1325 (205.3754)

02/07.2012

ELEMENTS DIMENSIONS FOR HF547-20

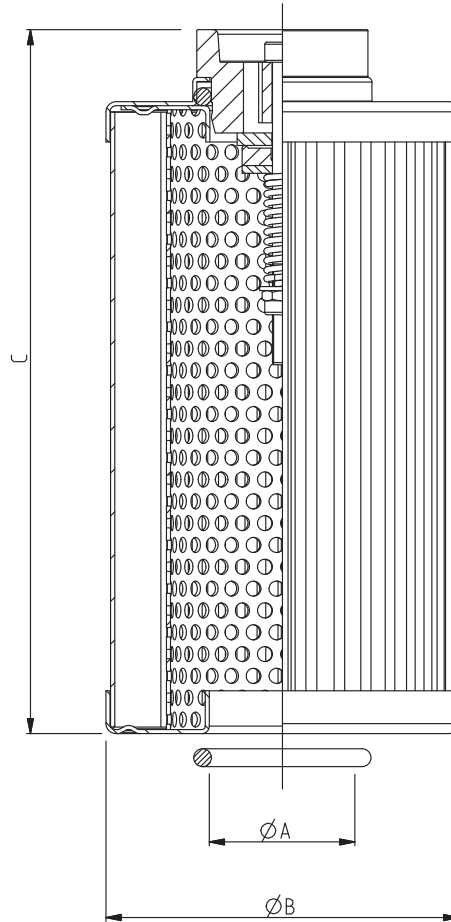

ICAT_021_004_HF547

Technical data for (FS) version elements are available on request.

02/07.2012

Element type	Ø A	Ø B	C	Filtering surface (AS)		
				FG	MI / MS	RP / SP
	mm (in)	mm (in)	mm (in)	cm ² (in ²)	cm ² (in ²)	cm ² (in ²)
HE K02-20.077	29 (1.1417)	70 (2.7558)	95 (3.7401)	700 (108.5002)	445 (68.9751)	850 (131.7503)
HE K02-20.122			140 (5.5117)	1115 (172.8253)	615 (95.3251)	1350 (209.2504)
HE K02-20.201	41 (1.6141)		219 (8.6220)	1680 (260.4005)	930 (144.1503)	2035 (315.4256)
HE K02-20.280			298 (11.7322)	2340 (362.7007)	1295 (200.7254)	2835 (439.4259)

INDICATORS

REAR MANOMETER

Code: **M**

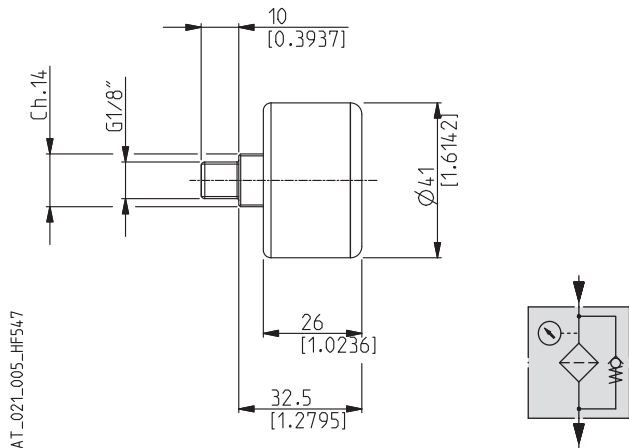

Scale $0 \div +145$ psi ($0 \div +10$ bar)

ICAT_021_005_HF547

RADIAL MANOMETER

Code: **N**

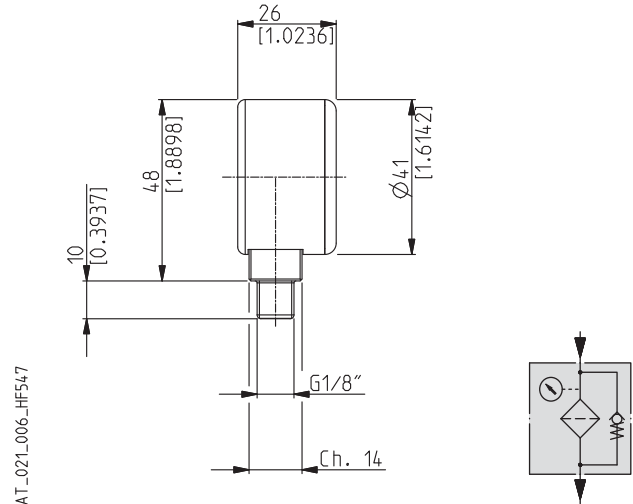

Scale $0 \div +145$ psi ($0 \div +10$ bar)

ICAT_021_006_HF547

VISUAL INDICATOR

Code: **P**

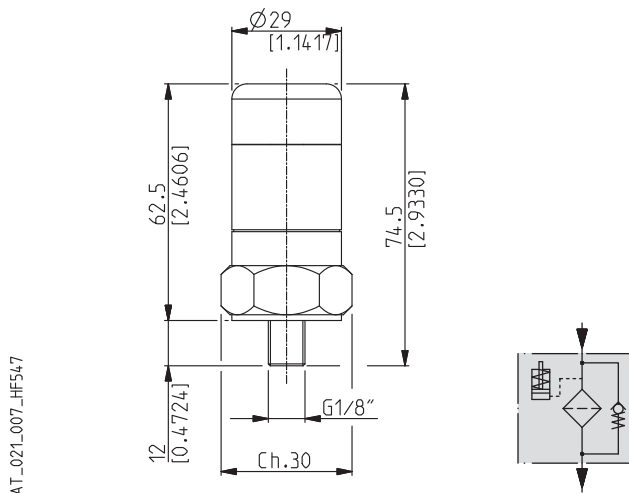

Pressure setting 21.8 psi (1.5 bar)

ICAT_021_007_HF547

ELECTRICAL INDICATOR

Code: **S**

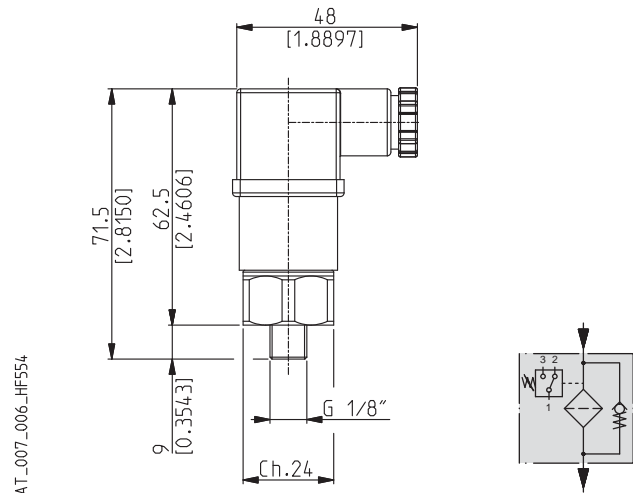

Pressure setting 21.8 psi (1.5 bar)

Max. working voltage

220 VCA
 30 VCC

Max. working current

$0,5$ A (resistivity)
 $0,15$ A (inductive)

Protection class

IP65

Contacts

N.O. and N.C.

ICAT_007_006_HF554

02/07.2012

INLET PORTS

Filter type	PORTS TYPE			
	Nominal size	Gas BSPP	NPT	SAE ODT
HF 547-10	3/8"	GC	NC	OA
	1/2"	GD	ND	OB
	3/4"	GE	NE	OD
HF 547-20	1/2"	GD	ND	OB
	3/4"	GE	NE	OD
	1"	GF	NF	OF
	1" 1/4	GG	NG	OG

GAS THREAD

BSPP

Cylindrical GAS thread (55°) in accordance with UNI - ISO 228

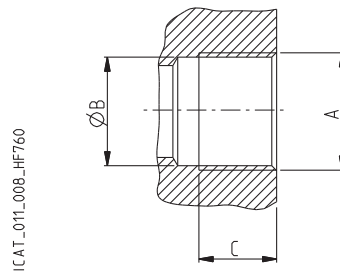

CODE	Nominal size	A	Ø B		C	Nm (lbf in)
			mm	(in)		
GC	3/8"	G 3/8	15	(0.5905)	14 (0.5511)	15 ⁺¹ (133 ÷ 142)
GD	1/2"	G 1/2	19	(0.7480)	17 (0.6692)	20 ⁺¹ (177 ÷ 186)
GE	3/4"	G 3/4	24,5	(0.9645)	20 (0.7873)	30 ^{+2,5} (266 ÷ 288)
GF	1"	G 1	30,5	(1.2007)	22 (0.8661)	50 ^{+2,5} (443 ÷ 465)
GG	1" 1/4	G 1 1/4	39	(1.5354)	24 (0.9448)	60 ⁺⁵ (531 ÷ 575)

02/07.2012

INLET PORTS

NPT THREAD

NPT

NPT thread (60°) in accordance with ANSI - ASME B1-20

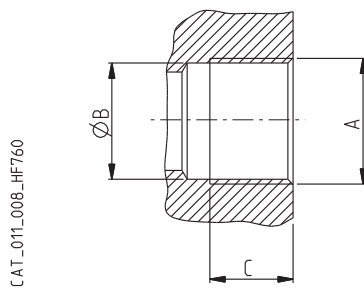

CODE	Nominal size	A	Ø B		C	Nm (lbf in)
			mm	(in)		
NC	3/8"	3/8 NPT	14,75	(0.5807)	10 (0.3936)	5 ⁺¹ (44 ÷ 53)
ND	1/2"	1/2 NPT	18	(0.7086)	13 (0.5118)	10 ⁺¹ (88 ÷ 97)
NE	3/4"	3/4 NPT	23,5	(0.9251)	14 (0.5511)	25 ⁺¹ (221 ÷ 230)
NF	1"	1 NPT	29,5	(1.1614)	17 (0.6692)	30 ^{+2,5} (265 ÷ 287)
NG	1" 1/4	1 1/4 NPT	38,5	(1.5157)	18 (0.7086)	50 ^{+2,5} (442 ÷ 464)

SAE J514 THREAD

ODT

American thread UNC-UNF 60° in accordance with ANSI B 1.1

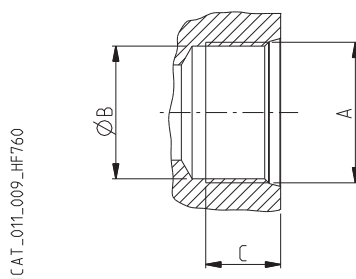

CODE	Nominal size	A	Ø B		C	Nm (lbf in)
			mm	(in)		
OA	3/8"	9/16" - 18 UNF- 2B	12,75	(0.5019)	12 (0.4724)	15 ⁺¹ (133 ÷ 142)
OB	1/2"	3/4" - 16 UNF - 2B	17,3	(0.6811)	15 (0.5905)	20 ⁺¹ (177 ÷ 186)
OD	3/4"	1 1/16" - 12 UNF - 2B	24,7	(0.9724)	20 (0.7873)	40 ^{+2,5} (354 ÷ 376)
OF	1"	1 5/16" - 12 UNF - 2B	30,5	(1.2007)	20 (0.7873)	60 ⁺⁵ (531 ÷ 575)
OG	1" 1/4	1 5/8" - 12 UNF - 2B	39,1	(1.5393)	20 (0.7873)	70 ⁺⁵ (620 ÷ 664)

02/07.2012

ASSEMBLY AND REPLACING ELEMENT INSTRUCTIONS

ASSEMBLY

Once you have checked the integrity of the filter inside its package, proceed as follows:

- A Take off the protection cap from the inlet port.
- B Ensure the filter to the tank through the flange's holes (pos.3) with a tightening torque of 44 lbf in (5 Nm).
- C Connect the circuit return pipes to the inlet port using the tightening torque indicated on pages 19 and 20.
- D Whether the filter has secondary ports, prepare the required connections.
- E If the filter has a clogging indicator (pos.10 - 11 - 12 - 13), take the protection cap off and screw the indicator in the dedicated seat, then tighten to a tightening torque of 266 lbf in (30 Nm). If the indicator is electric, complete the required connections.
- F Start the circuit for a few minutes.
- G Make sure there are no leaks.

REPLACING ELEMENT

Once the working hour limit indicated in the maintenance instructions of the system is reached or when the clogging indicators point out the limit pressure drop created inside the filter, the element must be replaced. Pay attention to the drainage of hydraulic oil, therefore prepare suitable containers to collect it. Each time the filtering element gets substituted we advise to change the air filter one too (pos.17).

Proceed as follows:

- A Stop the system in "Machine Stopped" status.
- B Secure any shut-off valves on the hydraulic circuit.
- C Unscrew the closure cover (pos.9).
- D Remove the clogged filtering cartridge (pos.6), making sure no residual particles have settled on the bowl bottom (pos.5).
- E Make sure the O-ring (pos.4 - pos.8) and the anti-extrusion ring (pos.1) are not damaged, otherwise replace them and consequently position the ones correctly.
- F Insert the new filtering cartridge, lubricating the sealing O-Ring beforehand.
- G Screw the cover (pos.9) making sure the threading is screwed correctly. Tighten to a tightening torque of 177 lbf in (20 Nm).
- H Re-open the eventual valves closed before.
- I Start the machine for a few minutes.
- L Make sure there are no leaks.

Pos.	Description
1	Housing seal
2	Antisplash
3	Housing
4	Bowl O-Ring
5	Bowl
6	Filtering element
7	Spring location
8	Cover O-ring
9	Closing cover
10	Radial manometer
11	Rear manometer
12	Electrical indicator
13	Visual indicator
14	Pressurized air breather junction
15	Pressurized air breather
16	Breather protection
17	Air breather element
18	Dipstick

When ordering spare parts, always specify the reference number, the filter code and quantity.
 Example: Spare parts pos. 8 - HHD20725 - Qty 3

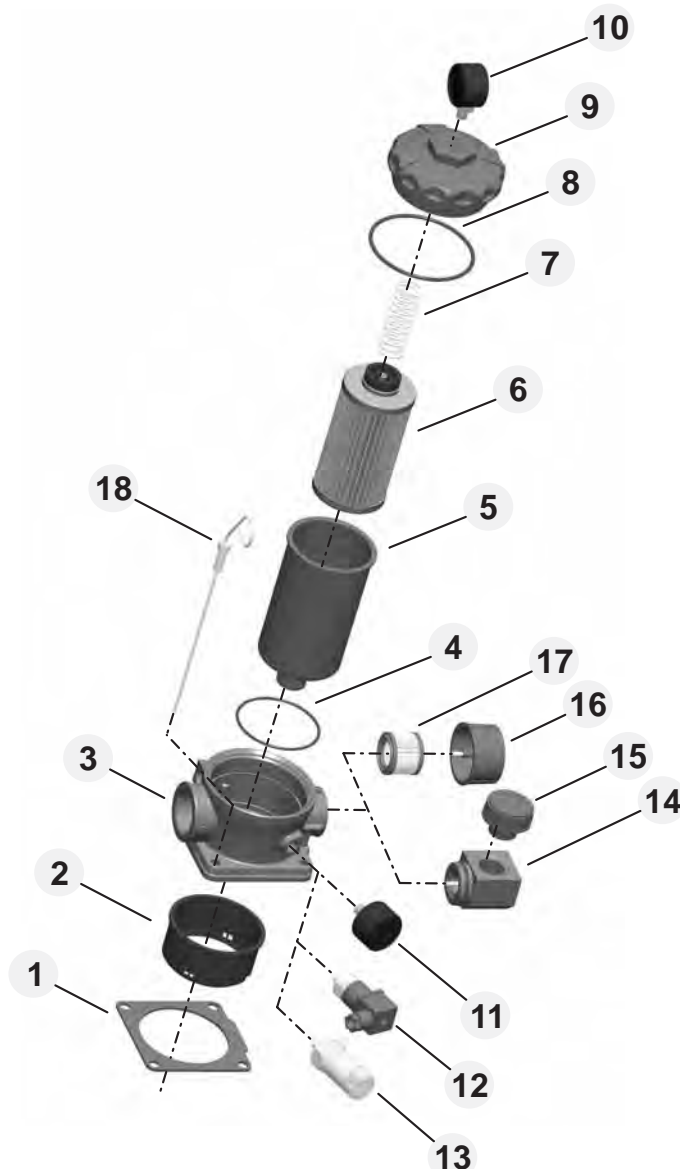

02/07.2012

HOW TO ORDER A COMPLETE FILTER

1	2	3	4	5	6	7	8		
HF547-	20.201	- AS	- FG010	- B17	- GG	- B	- S	- Z	-
9	10	11	12	13	14	15			
	XA	- GA	- M	- YC	- GC	- O	- K		

1	Filter type	CODE
	See table from pag. 14 to pag. 15	HF547..
2	Filtering surface	CODE
	Standard	AS
	Oversize	FS
3	Degree of filtration	CODE
	3 [µm] Micro-fibre glass	FG003
	6 [µm] Micro-fibre glass	FG006
	10 [µm] Micro-fibre glass	FG010
	25 [µm] Micro-fibre glass	FG025
	25 [µm] Stainless steel	MI025
	60 [µm] Stainless steel	MI060
	90 [µm] Steel	MS090
	125[µm] Stainless steel	MI125
	10 [µm] Cellulose	SP010
	25 [µm] Cellulose	SP025
	10 [µm] Reinforced cellulose	RP010
	25 [µm] Reinforced cellulose	RP025
4	By-pass setting valve	CODE
	With By-pass setting valve 25 [psi] (1,7 [bar])	B17
	With By-pass setting valve 51 [psi] (3,5 [bar])	B35
5	Inlet port	CODE
	GAS threads (BSPP)	
	G 3/8	GC
	G 1/2	GD
	G 3/4	GE
	G 1	GF
	G 1 1/4	GG
	NPT threads	
	3/8	NC
	1/2	ND
	3/4	NE
	1	NF
	1 1/4	NG
	SAE threads ODT	
	3/8	OA
	1/2	OB
	3/4	OD
	1	OF
	1 1/4	OG
6	Seals	CODE
	Buna	B
	Viton	V

7	Air breather	CODE
	Without	C
	With breather and filter 10 [µm]	S
	With breather and filter 40 [µm]	U
	With pressurized breather 4.4 psi (0,3 bar) and filter 40 [µm]	J
	With pressurized breather 4.4 psi (0,3 bar), pressurized suction -0.4 psi (0,03 bar) and filter 40 [µm]	W
8	Magnetic set	CODE
	Without	Z
	With magnetic set	R
9	Indicators arranged	CODE
	Without	XN
	On the housing - right (1)	XA
	On the housing - left (2)	XB
	On the cover (3)	XD
10	Indicators' ports dimensions	CODE
	GAS thread (BSPP)	
	G 1/8	GA
	G 1/8 with plug	DA
11	Indicators	CODE
	Without	G
	Manometer - rear connection	M
	Manometer - radial connection	N
	Visual indicator	P
	Electrical indicator	S
12	Secondary ports	CODE
	Without	YN
	On the housing - right (1)	YA
	On the housing - left (2)	YB
	On the housing - right (4) (only for HF547-20)	YC
13	Secondary ports dimensions	CODE
	G 1/4	GB
	G 3/8 (only for HF547-20)	GC
	G 1/2 (only for HF547-20)	GD
14	Antisplash	CODE
	Without	O
	With antisplash	A
15	Accessories	CODE
	Without	K
	With bowl extension (ex. bowl extension length 150=P150)	P...
	With level dipstick (ex. level dipstick length 175=L175)	L...

On request steel bowls for HF547-20 serie are available.

Standard On request

HOW TO ORDER A REPLACEMENT ELEMENT

1	2	3	4	5	6	
HEK02-	20.201	- AS	- FG010	- VM	- B17	- B

1	Element type	CODE
	See table from pag. 16 to pag. 17	HE K02..

2	Filtering surface	CODE
	Standard	AS
	Oversize	FS

3	Degree of filtration	CODE
	3 [µm] Micro-fibre glass	FG003
	6 [µm] Micro-fibre glass	FG006
	10 [µm] Micro-fibre glass	FG010
	25 [µm] Micro-fibre glass	FG025
	25 [µm] Stainless steel	MI025
	60 [µm] Stainless steel	MI060
	90 [µm] Steel	MS090
	125[µm] Stainless steel	MI125
	10 [µm] Cellulose	SP010
	25 [µm] Cellulose	SP025
	10 [µm] Reinforced cellulose	RP010
	25 [µm] Reinforced cellulose	RP025

4	By-pass valve	CODE
	With valve and spring	VM
	With valve - without spring	VV

5	By-pass setting valve	CODE
	With By-pass setting 25 [psi] (1,7 [bar])	B17
	With By-pass setting 51 [psi] (3,5 [bar])	B35

6	Seals	CODE
	Buna	B
	Viton	V

Standard
 On request

Building &
construction

Agriculture

Truck
Market

Material
Handling

Industrial

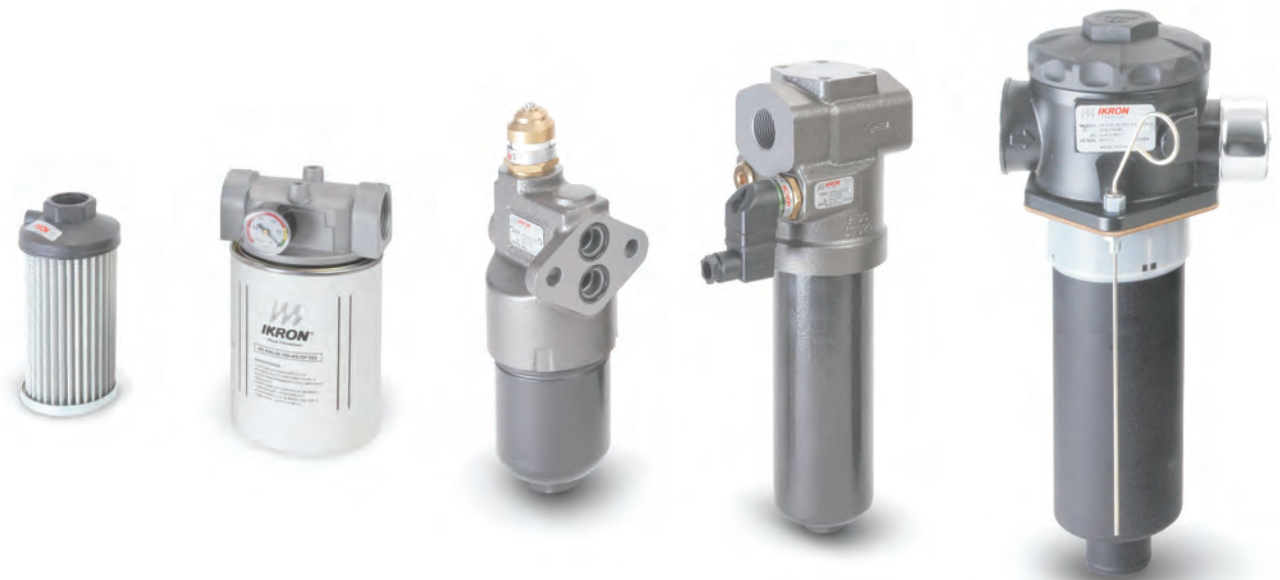

Full range of filters
for all hydraulic circuits

Suction filters

HF 410
HF 412
HF 431
HF 434
HF 437

Tank mounted return line filters

HF 502
HF 508
HF 547
HF 554
HF 570
HF 575
HF 578
HF 595

In line filters Spin-On

HF 620
HF 625
HF 650

In line medium and high pressure filters

HF 690
HF 705
HF 710
HF 725
HF 735
HF 745
HF 760
HF 761

Accessories

Filler breathers
Air filters
Level and temperature gauges
Pressure gauges
Pressure/vacuum gauges
Clogging indicators



IKRON S.r.l.

Via Prampolini, 2 - 43044 Lemignano di Collecchio - Parma - Italy

Tel.: + 39 0521 304911 - Fax: + 39 0521 304900

Videoconferencing IP

www.ikron.it

E-mail: info@ikron.it



Replaces: HF 547 01 T A

HF 547 02 T A Edition: 02/07.2012

