

Technical specifications

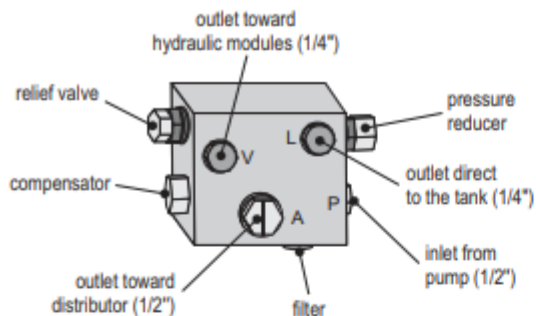

Max flow	70 l/min (A500020011)
Pressure working	210 bar in P 18 + 25 bar in V 1 bar in L
Maximum pressure	350 bar
Default filtering	ISO4406 18/14
Fluid	20-150 cSt
Body material	Aluminium
Weight	70 l/min : 1,2 Kg
Dimensions (mm)	70 l/min: 133x83x50

A500020011 - Max flow = 70 l/min

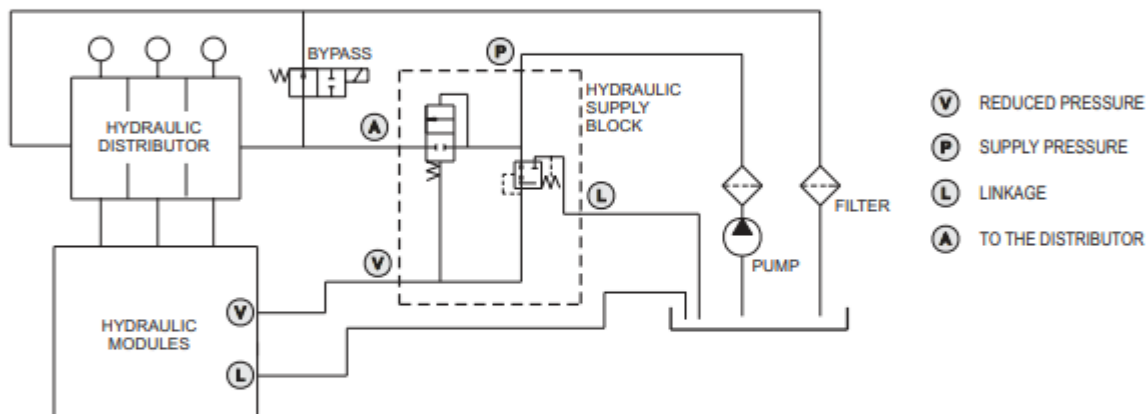

TYPICAL APPLICATION: HYDRAULIC CIRCUIT

